



Technical Bulletin

How to Read ICC-ES Evaluation Service® ESR-1539® Part VI Appendices A & B

Preface:

This is the last in a series of technical bulletins designed to provide a greater understanding of the ICC Evaluation Service® evaluation report ESR-1539® providing information on Appendix A; mathematical formulas for calculating fastener withdrawal, lateral design values for both nails and staples, specific gravity, dowel bearing strength and staple deformation information and Appendix B the recognized products of the listees in ESR-1539®.

The driven fasteners (nails and staples) described in the evaluation report are used in engineered and non-engineered (prescriptive) structural connections and are primarily installed using power tools. This technical bulletin references **ESR-1539® Reissue Date 07/2022**.
http://www.icc-es.org/Reports/pdf_files/ESR-1539.pdf

Background:

The first technical bulletin in this series, Terminology Used In ICC Evaluation Service® Report ESR-1539®, provides a brief description of several technical and administrative terms used.

Part I: Basic ESR Information covers the first four pages of ESR-1539® and provides insight on the format of the document, subject matter and product descriptions.

Part II: Fastener Basics and Tables 1-3 provides information on nail and staple terminology, collation, and the referenced codes in the evaluation report.

Part III: Fastener Withdrawal & Diaphragm Allowable Shear Tables addresses values for nail and staple withdrawal for a variety of wood specific gravities and

details on the allowable shear tables for wood structural products.

Part IV: Shear Wall Allowable Shear Tables provides information on shear walls made of wood structural products (plywood and OSB) and fiberboard sheathing, gypsum lath, and other materials.

Part V: Framing Tables addresses the different fasteners (code prescribed) and alternatives for the multiple framing connections referenced in the IBC® and IRC®.

Appendix A is divided into three major sections:

Section A1.0 Reference Design Values for Nailed Connections

Section A2.0 Reference Design Values for Stapled Connections

Section A3.0 Design Information for Deflection Calculations for Diaphragms and Shear Walls

Section A1.0 Reference Design Values for Nailed Connections

There are four primary topics covered in this section of the appendix. All of the equations in this section are derived from the National Design Specification (NDS®).

Sub Section A1.2 Reference Lateral Design Values:

Reference Lateral Design Value (Z) for nailed connections are calculated from six possible modes. The mode / equation with the lowest resulting value determines the anticipated value of (Z) to be used in the nailed connection. See Figure A for information regarding the six modes and representative equations.

A1.2 Reference Lateral Design Values:

Reference lateral design values are based on the yielding of connections as wood fibers are crushed and/or fastener shanks are bent. Reference lateral design values are determined from the lowest resulting value from six yield limit equations. These equations and depictions of these yield modes are shown below:

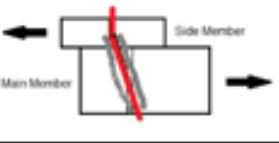
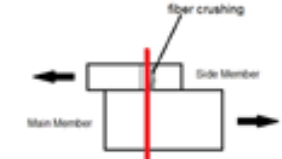
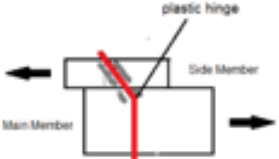
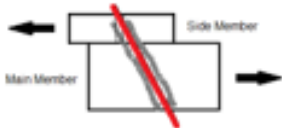
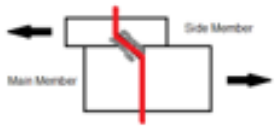
<p>For Mode I_{no}</p>  $Z = \frac{Dl_m F_{em}}{R_d}$	<p>For Mode III_{no}</p>  $Z = \frac{k_2 D l_m F_{em}}{(1 + 2R_e) R_d}$
<p>For Mode I_s</p>  $Z = \frac{D l_s F_{es}}{R_d}$	<p>For Mode III_s</p>  $Z = \frac{k_3 D l_s F_{es}}{(2 + R_e) R_d}$
<p>For Mode II</p>  $Z = \frac{k_4 D l_s F_{es}}{R_d}$	<p>For Mode IV</p>  $Z = \frac{D^2}{R_d} \sqrt{\frac{2F_{em} F_{yb}}{3(1+R_e)}}$

where:

$$K_1 = \frac{\sqrt{R_e + 2R_e^2(1+R_e+R_e^2) + R_e^2 R_e^2} - R_e(1+R_e)}{(1+R_e)}$$

$$K_2 = -1 + \sqrt{2(1+R_e) + \frac{2F_{em}(1+2R_e)D^2}{3F_{em}l_m^2}}$$

$$K_3 = -1 + \sqrt{\frac{2(1+R_e)}{R_e} + \frac{2F_{em}(2+R_e)D^2}{3F_{em}l_s^2}}$$

Z = Reference lateral design value, lbf

R_e = F_{em} / F_{es}

l_{no} = Length of nail in main member (member holding point), inches

l_s = Length of nail in side member, inches

F_{em} = Dowel bearing strength of main member (member holding point), psi [See 2018 and 2015 NDS Table 12.3.3 (2012 NDS Table 11.3.3)]

F_{es} = Dowel bearing strength of side member, psi [See 2018 and 2015 NDS Table 12.3.3 (2012 NDS Table 11.3.3)]

F_{yb} = Bending yield strength of nail, psi (see Appendix B)

D = Nominal nail diameter, inch (see Appendix B)

R_e = 2.2 for $D \leq 0.17"$, 10D + 0.5 for $0.17 < D < 0.25$

R_d = l_{no} / l_s

Figure A

Sub Section A1.3 Reference Withdrawal Design Values.

The equation for calculating withdrawal design values for Smooth or Deformed shank carbon steel nails, bright or galvanized (W) is:

$$W = 1380 G^{5/2} D \text{ in the in-pound system}$$

$$W = 9.515 G^{5/2} D \text{ in the SI system}$$

The equation for calculating withdrawal design values for Smooth or Deformed shank stainless steel nails, (W) is:

$$W = 465 G^{3/2} D \text{ in the in-pound system}$$

$$W = 3.026 G^{3/2} D \text{ in the SI system}$$

Where G is the wood specific gravity and D is the nominal diameter (inches or mm) of the nail shank. Specific gravity values for the various species of wood can be obtained from Table A in the appendix or in NDS® Table 12.3.3A. (2012 NDS does not address stainless steel nails) ESR-1539® Table 3 provides tabulated withdrawal values for various nail size / specific gravity combinations. Values shown are per inch of penetration.

Table A - Assigned Specific Gravity and Dowel Bearing Strength for Selected Wood Species

Data provided in Table A references the specific gravity of various species of wood, the Dowel Bearing Strength (F_e) of a nailed connection as listed in NDS® Table

12.3.3 and the Dowel Bearing Strength referenced in Acceptance Criteria AC201 Table 1.

The equation for determining Dowel Bearing Strength of a staple is:

$$F_e \text{ (stapled)} = F_e \text{ (nailed)} + 900$$

Section A2.0 Reference Design Values for Stapled Connections

Section A2.0 covers two primary topics
 A2.2 Reference Lateral; Design Values
 A2.3 Reference Withdrawal Design Values

Sub Section A2.2 Reference Lateral Design Values
 There are four equations that have been developed to determine the lateral design value. The minimum result obtained from the equations determines the anticipated design value for the connection (See Figure A)

Yield Mode I:

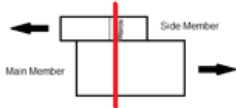

$$Z = \frac{2F_{es}l_s d}{K_D}$$

Yield Mode II:

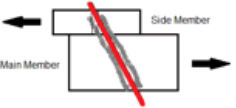

$$Z = \frac{2dF_{em}}{K_D} \left(\frac{l_m}{1 + \frac{F_{es}}{F_{em}}} \right) \left[\sqrt{\frac{F_{es}}{F_{em}} + 2 \left(\frac{F_{es}}{F_{em}} \right)^2 \left[1 + \frac{l_s}{l_m} + \left(\frac{l_s}{l_m} \right)^2 \right] + \left(\frac{F_{es}}{F_{em}} \right)^3 \left(\frac{l_s}{l_m} \right)^2} - \frac{F_{es}}{F_{em}} \left(1 + \frac{l_s}{l_m} \right) \right]$$

Yield Mode III:

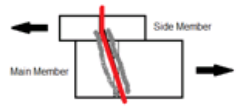

$$Z = \frac{2}{K_D} \left[\frac{-l_s F_{es} d}{2 \frac{F_{es}}{F_{em}} + 1} + F_{es} d \sqrt{\frac{l_s^2}{\left(2 \frac{F_{es}}{F_{em}} + 1 \right)^2} + \frac{l_s^2}{2 \frac{F_{es}}{F_{em}} + 1} + \frac{4M}{F_{es} d \left(2 \frac{F_{es}}{F_{em}} + 1 \right)}} \right]$$

Yield Mode IV:

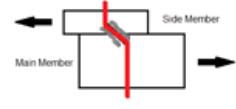

$$Z = \frac{4F_{em} d}{K_D} \sqrt{\frac{M}{F_{em} d \left(1 + \frac{F_{em}}{F_{es}} \right)}}$$

where:

- Z = Reference lateral design value for staple (2 legs), lbf.
- F_{em} = Dowel bearing strength of the main member, psi = 900 psi + F_e from 2018 and 2015 NDS Table 12.3.3 (2012 NDS Table 11.3.3, 2005 NDS Table 11.3.2) for D<1/4"
- F_{es} = Dowel bearing strength of the side member, psi = 900 psi + F_e from 2018 and 2015 NDS Table 12.3.3 (2012 NDS Table 11.3.3, 2005 NDS Table 11.3.2) for D<1/4"
- d = Nominal wire diameter, inch, from Table 3.2.
- M = Minimum staple bending moment, in-lbs, from Table 3.2.
- l_s = Length of staple in side member, inches.
- l_m = Length of staple in main member, inches, (minimum of 12D, where D is the nominal wire diameter from Table 3.2).
- K_D = Diameter coefficient for staple connections = 2.2

Figure A

Sub Section A2.3 Reference Withdrawal Design Values

The equation for calculating the withdrawal design values (W) for carbon steel bright or galvanized staples installed into the side grain of wood is:

$$W=2760 G^{5/2} D \text{ in the in-lb system}$$

$$W= 19.03 G^{5/2} D \text{ in the SI system}$$

Where G is the specific gravity of the wood and D is the nominal wire diameter in inches taken from Table 3.2 of ESR-1539.

Section A3.0 Design Information for Deflection Calculations for Diaphragms and Shear Walls

SDPWS has provisions for calculating the deflection in diaphragms and shear walls using nails in the connection and the reader of ESR-1539[®] is referred to sections 4.2.2 and 4.3.2 for additional information.

For stapled connections, the referenced equations for calculating deflection are contained in sections 2305.2 and 2305.3 of the IBC[®]. These equations make specific reference to staple deformation (e_n). Table B provides staple deformation values for 16, 15 and 14 gage staples at different staple leg lengths.

Appendix B Recognized Fasteners by Listees

Each member company of ISANTA that is listed in ESR-1539[®] receives a product listings table in Appendix B.

Appendix B begins with names of each listee and the page number associated with that company's listing. This is followed with a section on terminology used in individual listings such as Head Area Ratio (HAR) requirements, shank types and finish/coatings.

Nails listed in ESR-1539[®] intended for use in diaphragms, shear walls and braced walls (Lateral Force Resisting Assemblies or LFRA) are required to meet specific HAR requirements described in Acceptance Criteria AC116.

From AC116, "*For alternate head style variations such as clipped heads (for example D-Heads), the minimum head area ratio shall not be less than the minimum head area ratio for the code-prescribed nail of the same diameter.*"

Code-prescribed nails used in LFRAs are taken from ASTM F1667. These nails, referred to as common nails, have full round heads with specific dimensional diameters and tolerances. As ESR-1539[®] addresses a variety of alternative nails to the nails prescribed in the codes, nails may have heads which differ from those in F1667 Table 14.

Example: An 8d common nail (2½" x 0.131") with an ASTM head diameter of [0.253-0.309] inches has a HAR = 0.72

Nails with shank diameter of 0.131" for each listee were evaluated to determine the HAR value. If a listees 0.131" nail has a HAR equal to or greater than 0.72, a value of Y=8d is assigned to that nail indicating that the

nail meets the requirements for use in LFRAs where an 8d common nail is prescribed in the code.

A similar nomenclature applies to

6d common nails (2" x 0.113")	(Y=6d)
10d common (3" x 0.148")	(Y=10d)
16d common (3½" x 0.162")	(Y= 16d)
0.120" diameter nails	(Y120)
0.135" diameter nails	(Y135)
Nails not meeting requirements	(N)
Nails not applicable	(n/a)

Company Name						
Nails (Brand name: xxxx)						
TYPE OF COLLATION	NOMINAL DIAMETER (inch)	HEAD STYLE	MEETS HEAD AREA RATIO REQUIREMENTS FOR USE IN LFRAs	SHANK TYPE	FINISH / COATING	SPECIFIED BENDING YIELD STRENGTH, F_{yb} (psi)
Plastic Wire Paper	Typical diameters 0.092 0.099 0.113 0.120 0.131 0.135 0.148 0.162	Full Round Clipped Offset Round	n/a N Y=6d Y 120 Y=8d Y 135 Y= 10d Y= 16D	S - Smooth R – Ring Sc - Screw	X – Bright HDG – Hot Dip Galvanized EG – Electro-Galvanized MG – Mechanical Galvanized H – Hardened (bright) HT – Heat Treated (bright) HEG – Hardened Electro-galvanized HHDG – Hardened Hot Dip Galvanized HEG – Hardened Electro-Galvanized HTHDG – Heat Treated or hardened hot dip galvanized SS – Stainless Steel	Typical values 90,000 100,000 115,000 130,000
Metal Hardware Nails						
Designated 'xxx' on the package labeling						
Plastic Wire Paper	Typical diameters 0.131 0.148 0.162	Full Round	n/a	S - Smooth R – Ring Sc – Screw	X, HDG, EG, H, HT, HEG, HHDG HTHDG, SS	Typical values 90,000 100,000 115,000 130,000
STAPLE (Brand names: xxxxx)						
Gage	NOMINAL CROWN WIDTH (inch)			FINISH / COATING		
14 15 16	7/16 minimum allowed Others ½ - 1			X EG SS		

Listee Product Tables

The product listing table for each listee is broken down into several columns.

Column 1 indicates the type of nail collation: paper, plastic or wire as was previously discussed in Bulletin II.

Column 2 indicates the nominal diameter of the nail.

Column 3 indicates the style of head - full round, clipped, and offset (round).

Column 4 indicates whether the nail meets the HAR requirements for use in LFRAs

Column 5 indicates the type of nail shank available (S smooth shank, R ring shank, Sc screw shank).

Column 6 indicates type of finish / coating (X –bright, HDG – hot dip galvanized, EG – electro galvanized, SS – stainless steel, H – hardened. etc.

Column 7 indicates Bending Yield (F_{yb}) Strength.

Product tables for each listee are sorted by:

- Head Style (first)
- Nominal Shank Diameter (second)

For those listees who have staples in their listing, information regarding gage, nominal crown width and finish / coatings is listed on the bottom of their table.

Referenced Documents:

ANSI/AWC NDS-2018 National Design Specification for Wood © American Wood Council 2017

ASTM F1667/F1667M-21a Standard Specifications for Driven Fasteners: Nails, Spikes and Staples
© ASTM International December 2021

2021, 2018, 2015, 2012 International Building Code (IBC) © International Code Council Inc. ®

2021, 2018, 2015, 2012, International Residential Code (IRC) © International Code Council Inc. ®

AC116 ICC-ES Acceptance Criteria for Nails
© ICC Evaluation Service (ICC-ES) ® March 2021

AC201 ICC-ES Acceptance Criteria for Staples
© ICC Evaluation Service (ICC-ES) ® December 2020

ICC-ES Evaluation Report ESR-1539
© ICC Evaluation Service (ICC-ES) ® March 2021

A special thank you to Robert D. Tollefson, PE for his review of this document.

This technical bulletin is published by ISANTA for education and information only and is not intended as specific professional or technical advice. DO NOT ASSUME that all acceptable procedures are included here or that the information provided is appropriate for every situation.

ISANTA does not “approve” or “endorse” any specific products, services, companies, methods, processes, practices, or sources of information mentioned in the article, and the article should not be referenced in any way which would imply such approval or endorsement.

ISANTA DISCLAIMS ALL GUARANTEES OR WARRANTIES REGARDING THE ACCURACY OR SUFFICIENCY OF THE ARTICLE, AND ISANTA ASSUMES NO RESPONSIBILITY OR LIABILITY IN CONNECTION WITH THE USE, MISUSE, OR OMISSION OF ANY INFORMATION PROVIDED.

