



# Technical Bulletin

## Actuation Systems for Portable Compressed-Air-Actuated Fastener Driving Tools

### PREFACE:

International Staple, Nail and Tool Association (ISANTA) is the Sponsor / Standards-Developer for the American National Standard Institute, Inc. standard ANSI SNT-101-2015 Safety Requirements for Portable Compressed-Air-Actuated Fastener Driving Tools.

SNT-101-2015 sets forth safety requirements for portable, compressed-air-actuated fastener driving tools for manufacturers, owners, employers, designers, safety professionals and others when designing, using, maintaining and repairing these tools.

As such, SNT-101-2015 has some specific terminology regarding these tools. This bulletin addresses the types of actuation systems available in these types of tools.

### Basic Terminology:

**Actuate:** To cause movement of the tool components that are intended to drive a fastener.

**Fastener:** A staple, nail, pin, brad or other fastening designed and manufactured for use in the specified tool.

**Actuation System:** A trigger, workpiece contact and/or other operating control, used separately or in some combination or sequence, to actuate the tool.

Types of actuation systems (to be explained on subsequent pages)

- Full-Sequential Actuation
- Single-Sequential Actuation
- Contact Actuation
- Selective Actuation
- Automatic Reversion Actuation



## Full-Sequential Actuation:

- More than one operating control
- Operating controls must be activated in a specific sequence to actuate the tool
- If the tool has a trigger and a workpiece contact, the workpiece contact must be activated before the trigger for the tool to work
- Additional actuation can occur only when **all** operating controls are released and re-activated in the same sequence

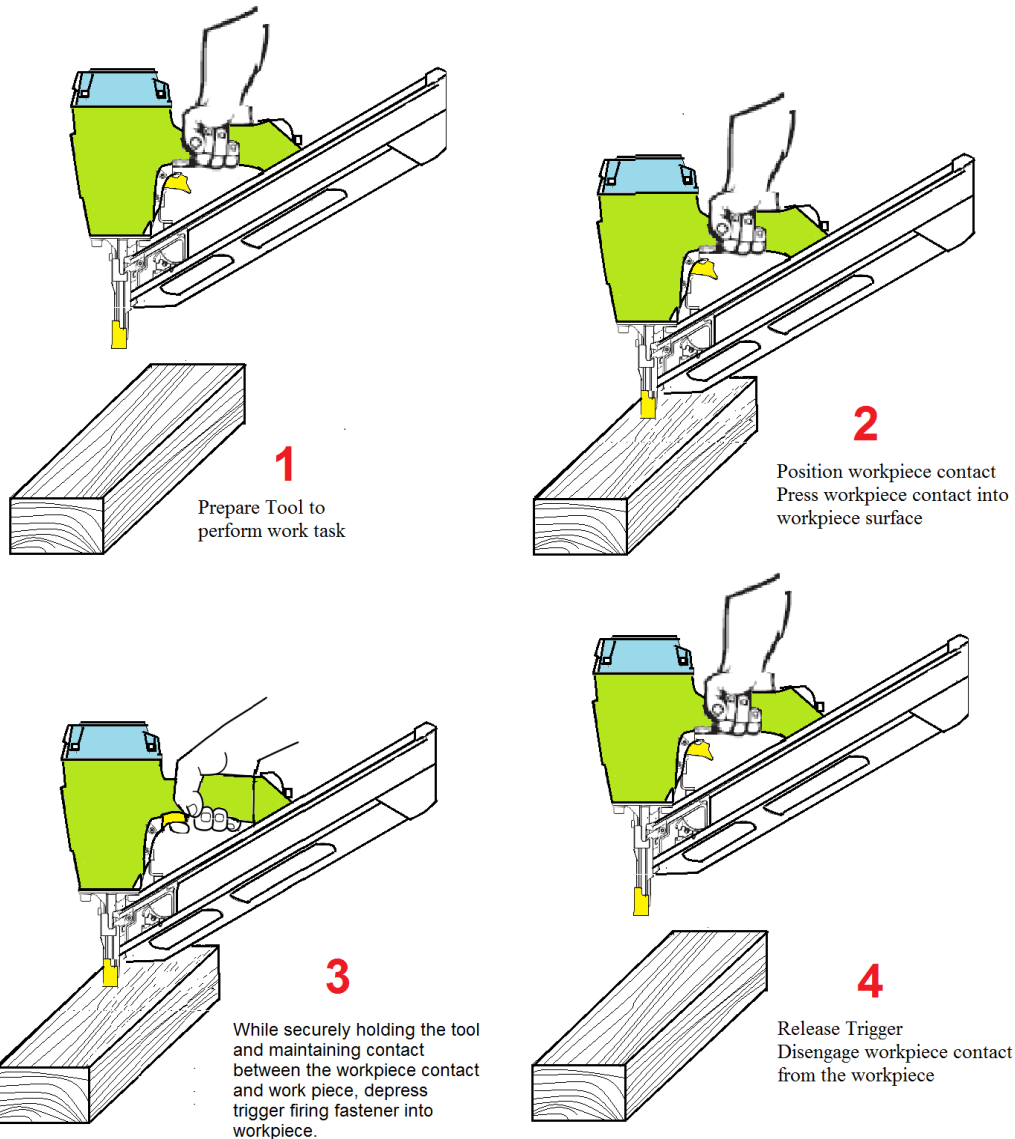

With this type of actuation, additional fasteners can only be fired after the trigger is released and the workpiece contact is disengaged from the workpiece surface.

## Single-Sequential Actuation:

- More than one operating control
- Operating controls must be activated in a specific sequence to actuate the tool
- If the tool has a trigger and a workpiece contact, the workpiece contact must be activated before the trigger for the tool to work
- Additional actuation can occur when a specific operating control, ***other than a workpiece contact*** is released and re-activated

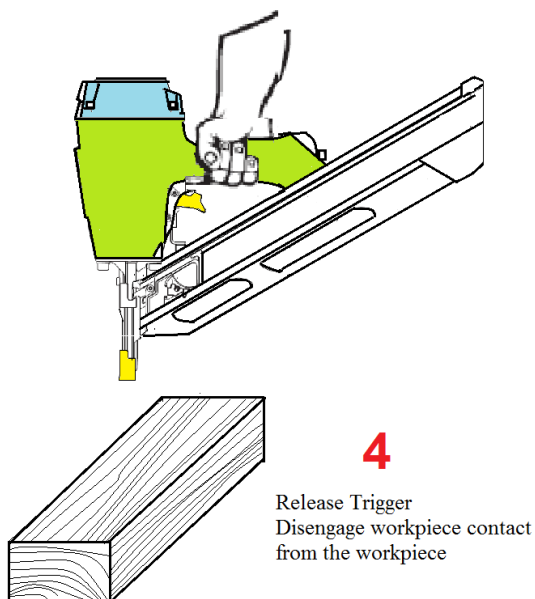
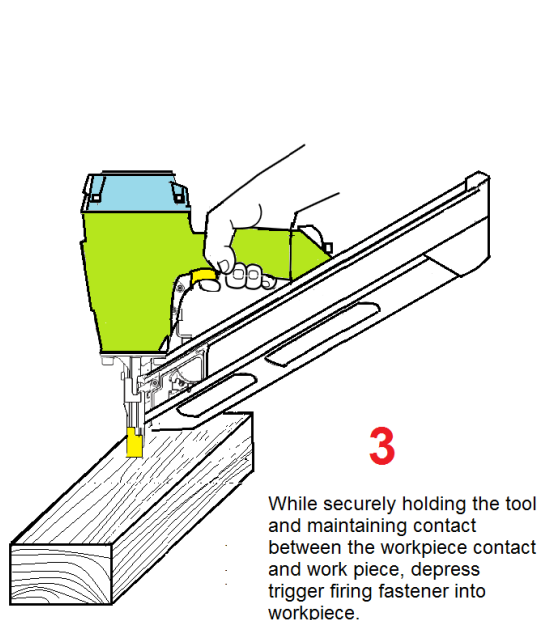
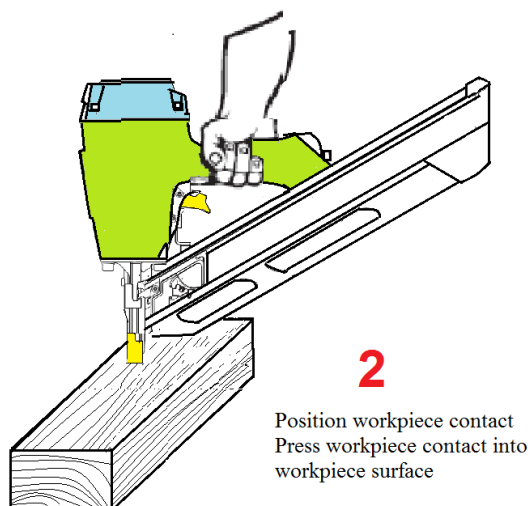
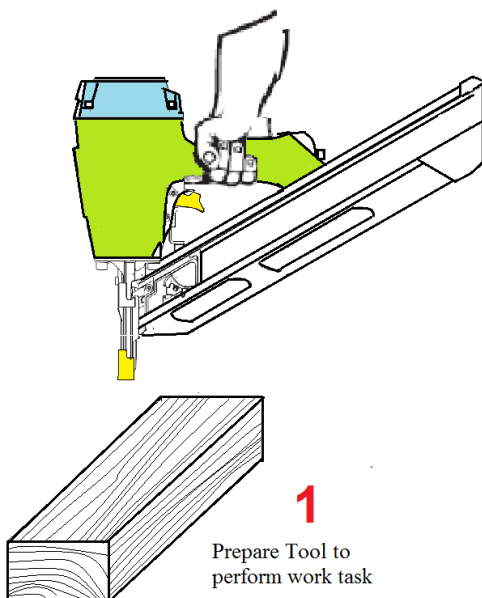

With this type of actuation, additional fasteners can be fired provided the trigger is released and the workpiece contact remains depressed and is in contact with the workpiece surface **or** provided both the trigger and the workpiece contact can be disengaged and reengaged in the same sequence.

## Contact Actuation (commonly referred to as bump fire or bounce fire)

- More than one operating control
- Operating controls can be actuated in **any** sequence
- Additional actuation can occur when any operating control is released and re-activated

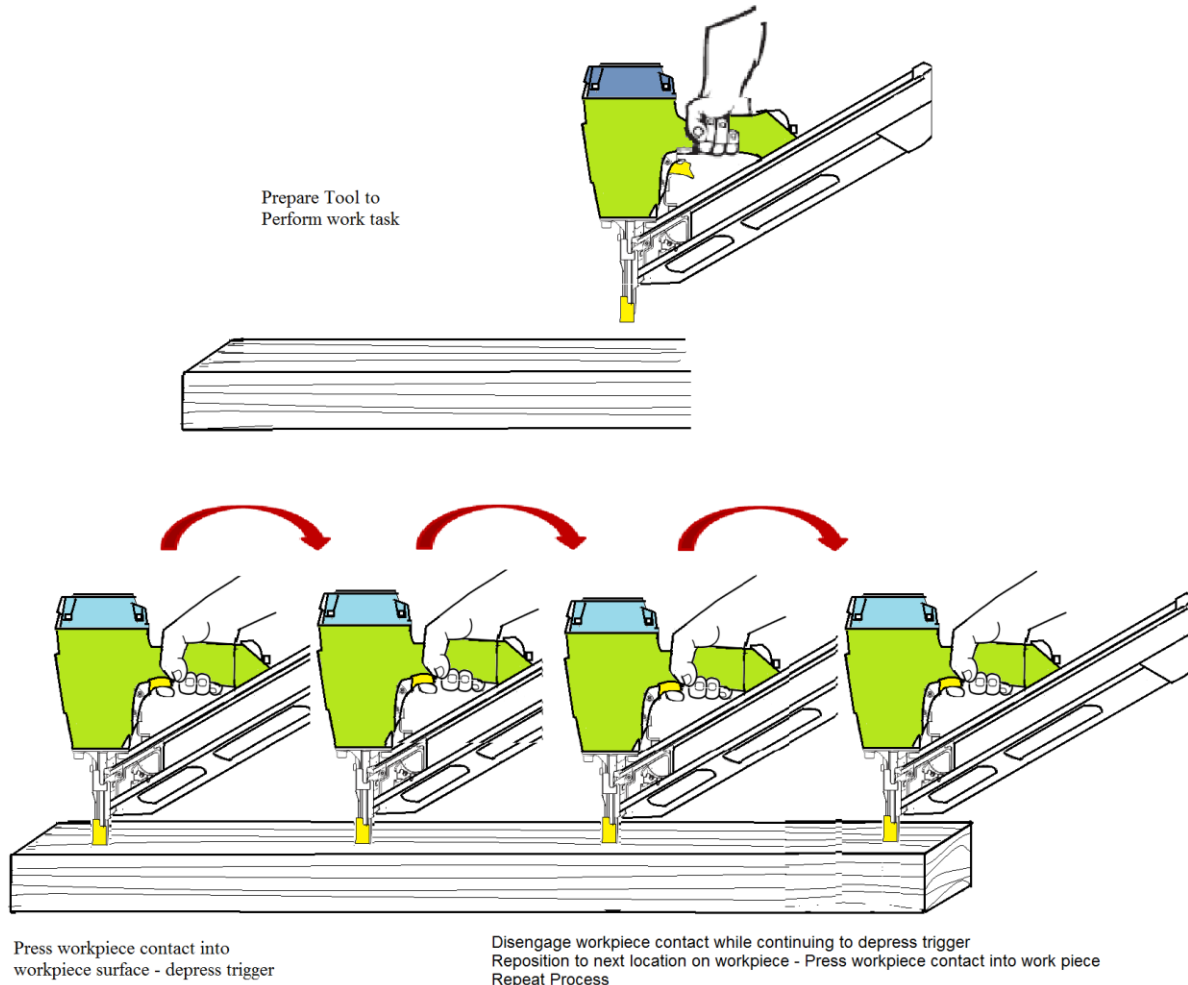

In this process shown above, the trigger is depressed and held, as the workpiece contact is bumped from point to point a fastener is fired from the tool.

### **Selective Actuation:**

- A system that allows discrete selection of two or more of the following actuation systems
  - Full-Sequential Actuation
  - Single-Sequential Actuation
  - Contact Actuation
- One or more shall be
  - Full-Sequential Actuation
  - Single-Sequential Actuation

The selector mechanisms on tools employing this actuation system are unique to each tool manufacturer. Read and understand the Operator's Manual for the tool being used.

### **Automatic Reversion Actuation:**

- An actuation system with more than one operating control
- Can be actuated in any sequence to actuate tool
- Regardless of the initial sequence, the actuation system is designed to automatically revert to
  - Full-Sequential Actuation
  - Single-Sequence Actuation
  - Neutral
  - Off

When using any tool, safety is paramount. Read and understand the Operator's Manual provided with your tool. Be aware of your surroundings. For additional Safety Tips, please see "Tool Safety Tips" on our website [www.isanta.org](http://www.isanta.org).

---

*This article is published by ISANTA for education and information only and is not intended as specific professional or technical advice. **DO NOT ASSUME** that all acceptable procedures are included here or that the information provided is appropriate for every situation.*

*ISANTA does not "approve" or "endorse" any specific products, services, companies, methods, processes, practices, or sources of information mentioned in the article, and the article should not be referenced in any way which would imply such approval or endorsement.*

*ISANTA DISCLAIMS ALL GUARANTEES OR WARRANTIES REGARDING THE ACCURACY OR SUFFICIENCY OF THIS TECHNICAL BULLETIN, AND ISANTA ASSUMES NO RESPONSIBILITY OR LIABILITY IN CONNECTION WITH THE USE, MISUSE, OR OMISSION OF ANY INFORMATION PROVIDED.*

---

